

Quality Uncompromised

ROTEL®

Technical Manual

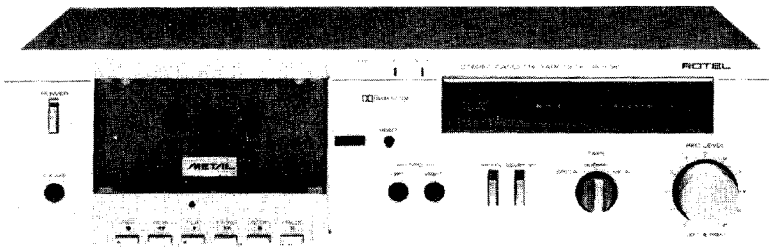

STEREO CASSETTE DECK RD-560

TABLE OF CONTENTS

Chassis Layout	2	Repair Parts List	8
Playback System Adjustments	3	Schematic Diagram	9
Recording System Adjustments	5	Wiring Diagram	11
REC/PB System Adjustments	6	Disassembly Diagram (1/2)	13
Block Diagram	7	Disassembly Diagram (2/2)	15

INHALTSVERZICHMIS

Chassis-Anordnung	2	Reparaturteilliste	8
Wiedergabepegels-Einstellung	3	Schaltungsschema	9
Aufnahmesystems-Einstellung	5	Drahtleitung Diagramm	11
Aufnahmesystems und Wiedergabepegels-Einstellung	6	Illustration des Auseinanderbaus (1/2)	13
Blockschaltbild	7	Illustration des Auseinanderbaus (2/2)	15

TABLE DES MATIERES

Installation du châssis	2	Liste des pièces de rechange	8
Réglages de système de la reproduction	4	Diagramme de schématique	9
Réglages de système de l'enregistrement	5	Diagramme de connexion	11
Réglages de système de L'enregistrement/reproduction	7	Schéma de démontage (1/2)	13
Schéma symoptique	7	Schéma de démontage (2/2)	15

THE ROTEL CO., LTD.
ROTEL ELECTRONICS CO., LTD.
ROTEL OF AMERICA, INC.
ROTEL HI FI LIMITED.

1-36-8 OHOKAYAMA, MEGURO-KU, TOKYO 152, JAPAN
2ND FLOOR, EVERGLORY BLDG., NO. 305, SECTION 3,
NANKING E. ROAD, TAIPEI, TAIWAN, REPUBLIC OF CHINA

13518 SO. NORMANDIE, GARDENA, CALIF. 90249, U.S.A.
2-4 ERICA ROAD, STACEY BUSHES, MILTON KEYNES,
BUCKINGHAMSHIRE, ENGLAND

Printed in Taiwan '81 Sep. 835201395

Chassis Layout / Chassis - Anordnung / Installation de Châssis

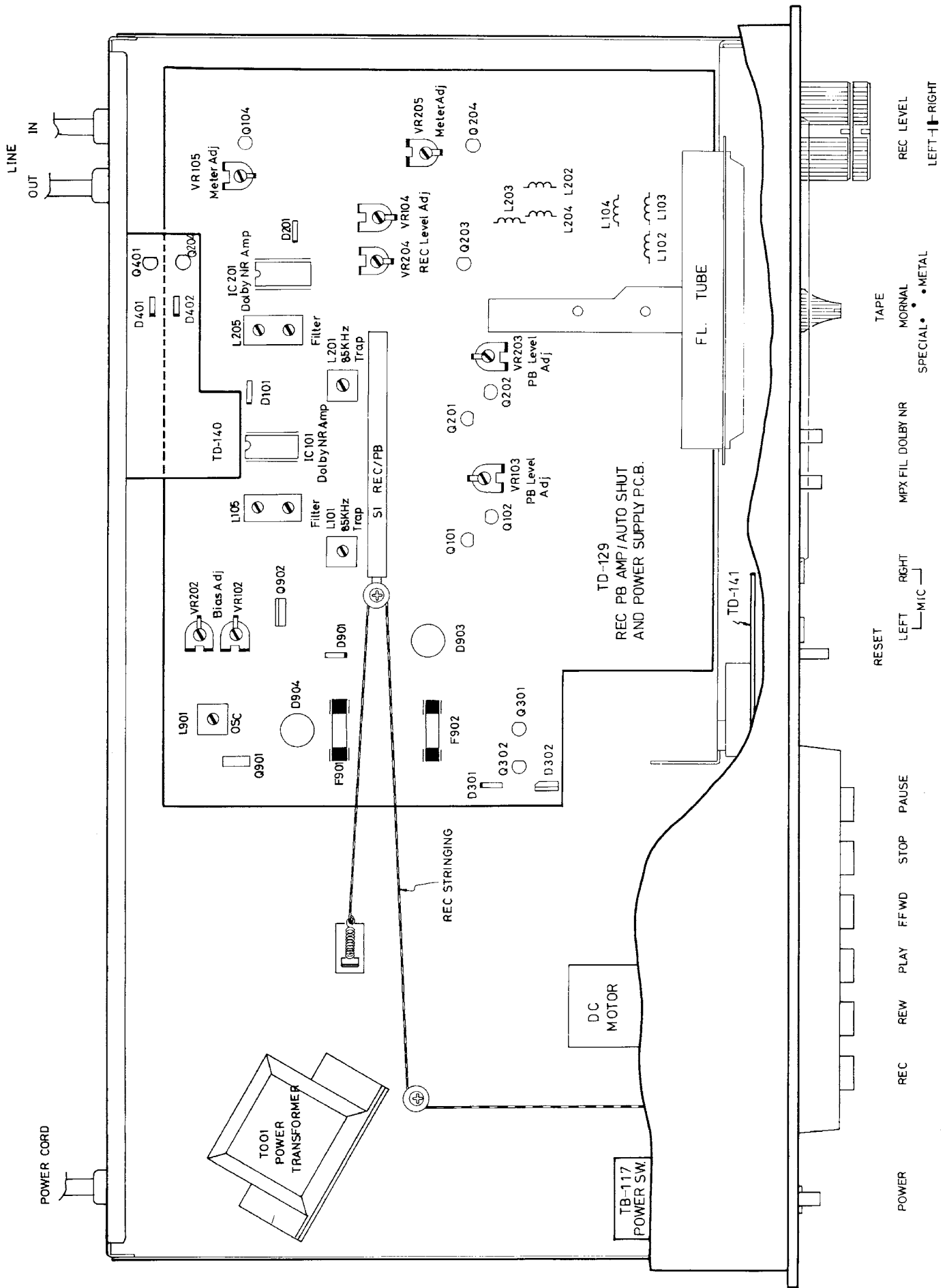

Playback System Adjustments

Instruments: Oscilloscope, AC VTVM, Frequency Counter and Test Tape

Conditions: Oscilloscope, AC VTVM and Frequency Counter . . . LINE OUT Tape Selector . . . NORMAL Dolby NR . . . OFF

Adjustment Item	Test Tape	Adjust	Adjust for
Azimuth	LCT-3004-C	REC/PB head screw	Obtain largest wave form on Oscilloscope for both channels (Fig. 1)
Dolby Level	LCT-7001	VR103 (L-ch) VR203 (R-ch)	AC VTVM reads 580mV
FL Tube Calibration		VR105 (L-ch) VR205 (R-ch)	The FL Tube indicator corresponds with the Dolby mark (Fig. 2)
Playback EQ Check	LCT-3009-C	Output Level difference between 40Hz, 1KHz and 10KHz signal is within ± 2.0 dB	
Tape Speed Deflection Check/Tape Speed Adjust	LCT-3001	Check that allowable margin of deflection at middle of or at the end of winding is in the range of +2%–1% (at 3000Hz allowable margin of deflection of speed is 3060-2970) If Tape Speed deflection surpasses the above range adjust speed of Motor (Fig. 3)	

Wiedergabepegels-Einstellung

Instrumente: Oszillograph, Wechselspannungsvoltmeter, Frequenz-Zähler und Test-cassette

Bedienung: Oszillograph, Wechselspannungsvoltmeter und Frequenz-Zähler . . . LINE OUT, Bank-Wahler . . . NORMAL

Dolby NR Taste . . . OFF

Einstellungsteil	Test-Cassette	Einstellung	Einstellungszweck
Azimut	LCT-3004-C	REC/PB Tonkopfschraube	Maximum-Wellenform auf Oszillograph für beiden Kanäle (Abb. 1) erhalten.
Dolby-Regel	LCT-7001	VR103 (L-K) VR203 (R-K)	Wechselspannungsvoltmeter auf 580mV einstellen.
Zähler- FL Tube		VR105 (L-K) VR205 (R-K)	Der FL Tube -Anzeiger auf dem Dolby-Zeichen steht. (Abb. 2)
Prüfung der Wiedergabe "EQ"	LCT-3009-C	Ausgangspegelunterschied zwischen 40Hz, 1KHz und 10KHz darf innerhalb + 2.0dB betragen.	
Überprüfung der Bandgeschwindigkeit /Einstellung der Bandgeschwindigkeitabweichung	LCT-3001	Prüfen, ob Abweichung von der Sollgeschwindigkeit im Bereich + 2% - 1% liegt (bei 3000 Hz zwischen 3060-2970 Hz). Bei grösser Abweichung Motorgeschwindigkeit nachstellen (Abb. 3)	

- Réglages de système de la reproduction

Instruments: Oscilloscope, Voltmètre électronique à courant alternatif, Analyseur de fréquence et bande d'essai.

Conditions: Oscilloscope, Voltmètre électronique à courant alternatif et analyseur de fréquence LINE OUT
selecteur de bande NORMAL Dolby NR OFF

Item de réglage	Bande d'essai	Régler	Régler pour
Azimuth	LCT-3004-C	Vis de tête de Enregistrement/reproduction	Obtenir forme d'onde la plus grande sur l'oscilloscope pour les deux canaux (fig. 1)
Niveau de Dolby	LCT-7001	VR-103 (canal gauche) VR-203 (canal droit)	Le voltmètre électronique à courant alternatif lit 580 mV.
Calibrage de FL Tube		VR 105 (canal gauche) VR-205 (canal droit)	FL Tube Indicateur correspond à la marque Dolby (fig. 2)
Contrôle de l'égalisation de reproduction	LCT-3009-C	Différence de niveau de sortie entre les signaux 40 Hz, 1 KHz et 10KHz est dans ± 2.0 dB.	
Contrôle de la Variation de la vitesse de bande/réglage de la vitesse	LCT-3001	Vérifier que la marge admissible de variation au milieu ou à la fin de bobinage est dans la plage donnée de $+2\% - 1\%$ (à 3000 Hz marge admissible de variation de la vitesse est 3060-2970). Si la variation de vitesse de bande surpasse la plage donnée ci-dessus, régler la vitesse de moteur. (fig. 3)	

FRONT CHASSIS VIEW

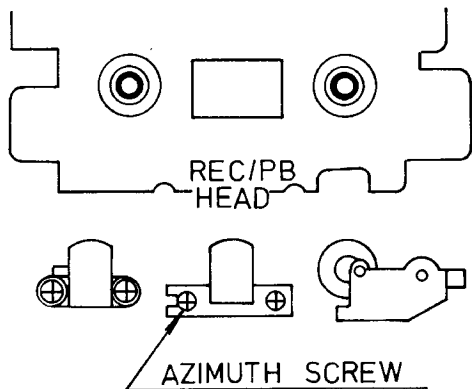

ADJUST AZIMUTH SCREW TO OBTAIN
MAXIMUM DEFLECTION ON SCOPE

Fig. 1 Azimuth Adjustment
Abb. 1 Azimuteinstellung
Fig. 1 Réglage de l'azimut



ADJUST POTENTIOMETER VR105
(VR205 FOR R-CH) SO THAT FL-
UORESCENT LIGHT TUBE SHOWS
LEVEL FROM -20dB TO 0dB.

Fig.2 Dolby Level Adjustment
Abb. 2 Einstellung der Dolby-Regel.
Fig. 2 Réglage du niveau Dolby

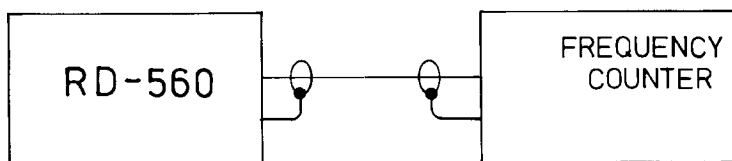
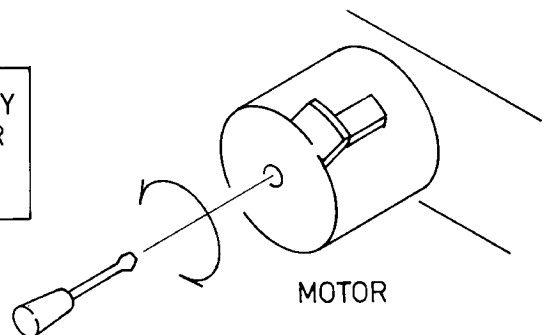

Fig. 3 Tape speed Adjustment
Abb. 3 Einstellung der Bandgeschwindigkeitabweichung
Fig. 3 Réglage de la vitesse de défilement de la bande



Recording System Adjustments

Instruments: Oscilloscope, Signal Generator, AC VTVM and Blank Tape

Conditions: Dolby NR ... OFF REC Level ... Maximum

Adjustment Item	Coupling	Tape Selector	Adjust	Adjust for
Bias Carrier	Oscilloscope ... Point TP 1 (TP 2 R-ch)	METAL	L 101 (L-ch) L 201 (R-ch)	Obtain Min. deflection on the Oscilloscope
19KHz Filter	S.G. (400Hz 0dB) ... LINE IN/LINE OUT ... 410mV Changed S.G. to 19KHz Dolby NR ... ON	NORMAL	L 105 (L-ch) L 205 (R-ch)	AC VTVM reads -30dB (Minimum)
Bias Voltage	Oscilloscope ... Point 1 (2 R-ch)	METAL	VR 102 (L-ch) VR 202 (R-ch)	AC VTVM reads 6mV

Aufnahmesystems-Einstellung

Instrumente: Oszillograph, NF-Generator, Wechselspannungsvoltmeter und Leercassette.

Bedienungen: Dolby NR Taste ... OFF Aufnahmepegelregler ... Maximum

Einstellungsteil	Kupplung	Band-Wähler	Einstellung	Einstellungszweck
Bias-Trägerstrom	Oszillograph ... Punkt TP 1 (TP 2 R-K)	METAL	L 101 (L-K) L 201 (R-K)	Min. Abweichung auf Oszillograph erhalten.
19KHz Filter	NF-Generator (400Hz 0dB) ... an "LINE IN/LINE OUT ... 410mV NF-Generator auf 19 KHz. Dolby NR ... ON	NORMAL	L 105 (L-K) L 205 (R-K)	Wechselspannungsvoltmeter auf -30dB einstellen, (Minimum)
Vorspannung	Oszillograph ... Punkt 1 (2 R-K)	METAL	VR 102 (L-K) VR 202 (R-K)	Wechselspannungsvoltmeter auf 6mV einstellen.

Réglages de système de l'enregistrement

Instruments: Oscilloscope, Générateur de signal, voltmètre électronique à courant alternatif et bande vierge

Conditions: Dolgy NR ... OFF Niveau de l'enregistrement ... maximum

Item de réglage	Accouplement	Selecteur de bande	Régler	Régler pour
Porte-Polarisation	Oscilloscope ... Point TP 1 (TP 2 canal droit)	METAL	L-101 (canal gauche) L 201 (canal droit)	Obtenir la variation min. sur l'oscilloscope
Filtre 19KHz	Générateur de signal (400Hz 0dB) ... LINE IN/LINE OUT ... 410mV Changé le générateur de signal à 19KHz Dolby NR ... ON	NORMAL	L 105 (canal gauche) L 205 (canal droit)	Voltmètre électronique à courant alternatif lit -30dB (minimum)
Voltage de polarisation	Oscilloscope ... Point 1 (2 Canal droit)	METAL	VR 102 (canal gauche) VR 202 (canal droit)	Voltmètre électronique à courant alternatif lit 6mV

REC/PB System Adjustments

Instruments: Signal Generator, H.D. Analyzer and Blank Tape

Conditions: Dolby NR . . . OFF REC Level . . . Maximum PLAY, REC, PAUSE . . . ON

Adjustment	Conditions	Adjust	Adjust for
REC/PB Output Level	S.G. (400Hz 0dB) . . . LINE IN/LINE OUT . . . 410mV Release Pause Button and playback it again.	VR 104 (L-ch) VR 204 (R-ch)	Recording and Playback level difference must be within ± 1 dB
Distortion Check	S.G. (400Hz 0dB) . . . LINE IN/LINE OUT . . . 410mV H.D.Analyzer . . . LINE OUT Release Pause Button and playback it again.	Check that distortion is within following range. a. METAL Tape under 1.5% b. CrO2 Tape under 3% c. NORMAL Tape. under 1.5%	
	If the distortion factor exceeds the above, recheck Bias Current Adjustment.		
Frequency Response Check	METAL Tape insert it	VR 102 (L-ch) VR 202 (R-ch)	40Hz–125Hz . . . 5dB 125Hz–10KHz . . . 3dB 10KHz–15KHz . . . 5dB
	CrO2 Tape insert it		
	NORMAL Tape insert it		40Hz–125Hz . . . 5dB 125Hz–10KHz . . . 3dB 10KHz–14KHz . . . 5dB

Aufnahmesystems-und Wiedergabepegels-Einstellung

Instrumente: NF-Generator, Klirrfaktormessbrücke und Leer-cassette

Bedienungen: Dolby NR . . . OFF

Aufnahmespegel . . . Maximum

PLAY, REC, PAUSE Taste ON

Einstellung	Bedienungen	Einstellen	Einstellungszweck
Aufnahme/Wiedergabe Ausgangspegel	NF-Generator (400 Hz 0dB) . . . LINE IN/LINE OUT . . . 410mV. Pause-Taste freigeben und spielen es rück noch einmal.	VR 104 (L-K) VR 204 (R-K)	Die Differenz der Aufnahme und Wiedergabe-Ausgangspegel innerhalb einer Toleranz von ± 1 dB liegen müssen.
Prüfen des Klirrfaktors	NF-Generator (400 Hz 0dB) . . . LINE IN/LINE OUT . . . 410mV. Klirrfaktormessbrücke . . . LINE OUT Pause-Taste freigeben und spielen es rück noch einmal.	Prüfen, ob Klirrfaktor den folgenden Werten entspricht: a. METAL Band unter 1.5% b. CrO2 Band unter 3% c. NORMAL Band. unter 1.5%	
	Wenn der Klirrfaktor die angegebenen Werte übersteigt, dann Vormagnetisierungstrom prüfen.		
Prüfen des Frequenzgangs	METAL Band einschieben	VR 102 (L-K) VR 202 (R-K)	40Hz–125Hz . . . 5dB 125Hz–10KHz . . . 3dB 10KHz–15KHz . . . 5dB
	CrO2 Band einschieben		
	Normal Band einschieben		40Hz–125Hz . . . 5dB 125Hz–10KHz . . . 3dB 10KHz–14KHz . . . 5dB

Réglages de système de l'enregistrement/reproduction

Instruments: Générateur de signal, analyseur H.D., et bande vierge

Conditions: Dolby NR . . . OFF

Niveau de l'enregistrement . . . maximum

Reproduction, enregistrement, pause . . . ON

Réglage	Conditions	Régler	Régler pour
Niveau de la sortie de l'enregistrement/reproduction	Générateur de signal (400 Hz 0dB) ... LINE IN/LINE OUT ... 410 mV Relâcher le bouton de pause et reproduire encore.	VR 104 (canal gauche) VR 204 (canal droit)	Différence de niveau de l'enregistrement et reproduction doit être dans ± 1 dB.
Contrôle de la déformations	Générateur de signal (400 Hz 0dB) ... LINE IN/LINE OUT ... 410 mV Analyseur H.D. ... LINE OUT Relâcher le bouton de pause et reproduire encore.	Vérifier que la déformation est dans la plage donnée suivante. a. Bande métale sous 1.5% b. Bande CrO2 sous 3% c. Bande normale sous 1.5%	
	Si le facteur de la déformation excède les valeurs ci-dessus, vérifier le réglage du courant de la polarisation.		
Contrôle de réponse de fréquence	Insérer la bande METAL	VR 102 (canal gauche) VR 202 (canal droit)	40Hz-125Hz ... 5dB 125Hz-10Hz ... 3dB 10KHz-15KHz ... 5dB.
	Insérer la bande CrO2		
	Insérer la bande NORMAL		40Hz-125Hz ... 5dB 125Hz-10KHz ... 3dB 10KHz-14KHz ... 5dB.

Block Diagram/Blockschaltbild/ Schéma synoptique

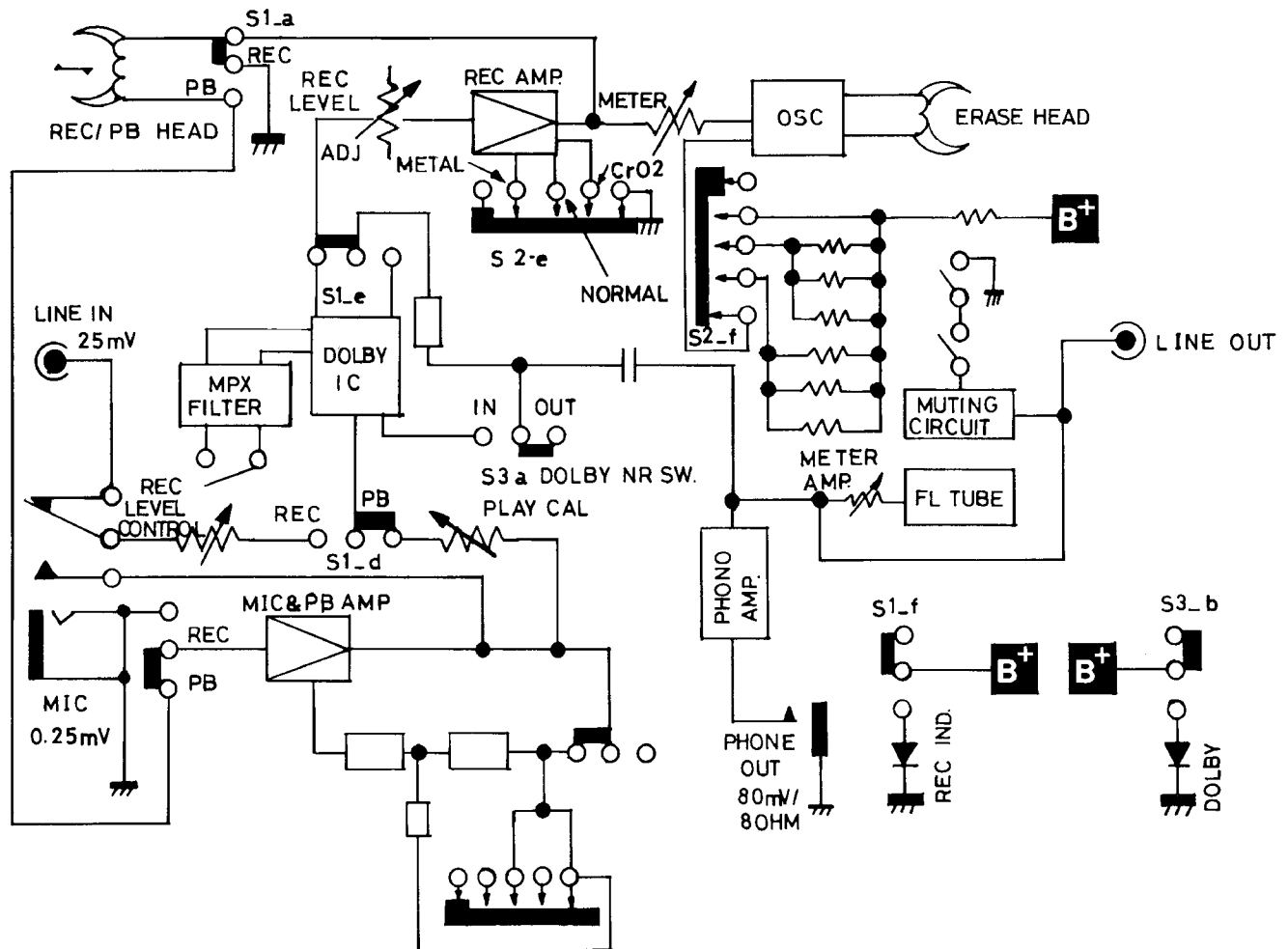

Repair Parts List/Reparaturteilliste/ Liste des pieces de rechange

Schematic Location	Parts No.	Description
TRASISTORS, DIODES AND IC'S		
Q101-103		
Q201-203	301201222	2SC2634NC (S,T), MIC/REC Amp.
Q104, 204	301201132	2SC1384 (S), Phone Amp.
Q301, 302	301901132	LC945 (P,K), for Auto-Stop
Q403, 404	301901132	LC945 (P,K), F.L. Tube Amp.
Q901	301201223	2SC2590, OSC
Q902	301201169	2SC1826 (Y,O), Stabilizer
D101, 201	300111018	1S1588, Reversal Provention
D301	300919026	1N4003, Rectifier
D302	300515003	2PO5M, Auto-Stop Control
D401-403	300313039	RD-3.6EC, Zener Diode
D901	300313016	WZ-210, Zener Regulator 21V 1/2W
D903, 904	300919011	W02, Regulator
D001	300414051	LT-13217, REC Ind.
D002	300414052	LT-13237, Dolby NR Ind.
D003	300414051	LT-13217, Pause Ind.
D004	300414051	LT-13217, Power Ind.
IC101, 201	303452218	NE646B, REC/PB Amp.
COILS AND VARIABLE RESISTORS		
L101, 201	228641174	85KHz, Trap Coil
L102, 103 202, 203	228641172	6.8mH, Peaking Coil
L104, 204	228641173	10mH, Peaking Coil
L105, 205	228641189	Filter
L901	228641190	OSC
VR101	525101174	50KA x 2, REC Level Control
VR102, 202	510502196	100KB, Bias Adj.
VR103, 203	510502200	50KB, PB Level Adj.
VR104, 204	510502199	20KB, REC Level Adj.
VR105, 205	510502195	10KB, F.L. Tube Level Adj.

Schematic Location	Parts No.	Description
SWITCHES AND FUSES		
S1	613000041	Switch, Slide, REC/PB
S2	601011332	Switch, Tape Selector
S3,4	614020455	Switch, Push 2-Key, Dolby NR, MPX Fil.
S5	614010165	Switch, Power Supply (for BEAB...)
	614010168	Switch, Power Supply (for UL, CSA)
T001	207001540	Transformer, Power Supply (120V only)
	207001539	Transformer, Power Supply (220, 240V)
F401	341240002	Fuse, 0.2A, AC Circuit Protector (Long Size)
	345220002	Fuse, 200mA, AC Circuit Protector (Mini Size)
	345250002	Fuse, F200mA, AC Circuit Protector (Mini Size "S" "D" mark)
F902	341240005	Fuse, 0.5A, AC Circuit Protector (Long Size)
	345220005	Fuse, 500mA, AC Circuit Protector (Mini Size)
	345250005	Fuse, F500mA, AC Circuit Protector (Mini Size "S" "D" mark)
F903	341240010	Fuse, 1A, AC Circuit Protector (Long Size)
	345220010	Fuse, 1A, AC Circuit Protector (Mini Size)
	345250010	Fuse, F1A, AC Circuit Protector (Mini Size "S" "D" mark)

Schematic Diagram/Schaltungsschema/Diagramme.sché

NOTE: PARTS CIRCUIT SUBJECT TO CHANGES FOR IMPROVEMENTS WITHOUT PRIOR NOTICE.

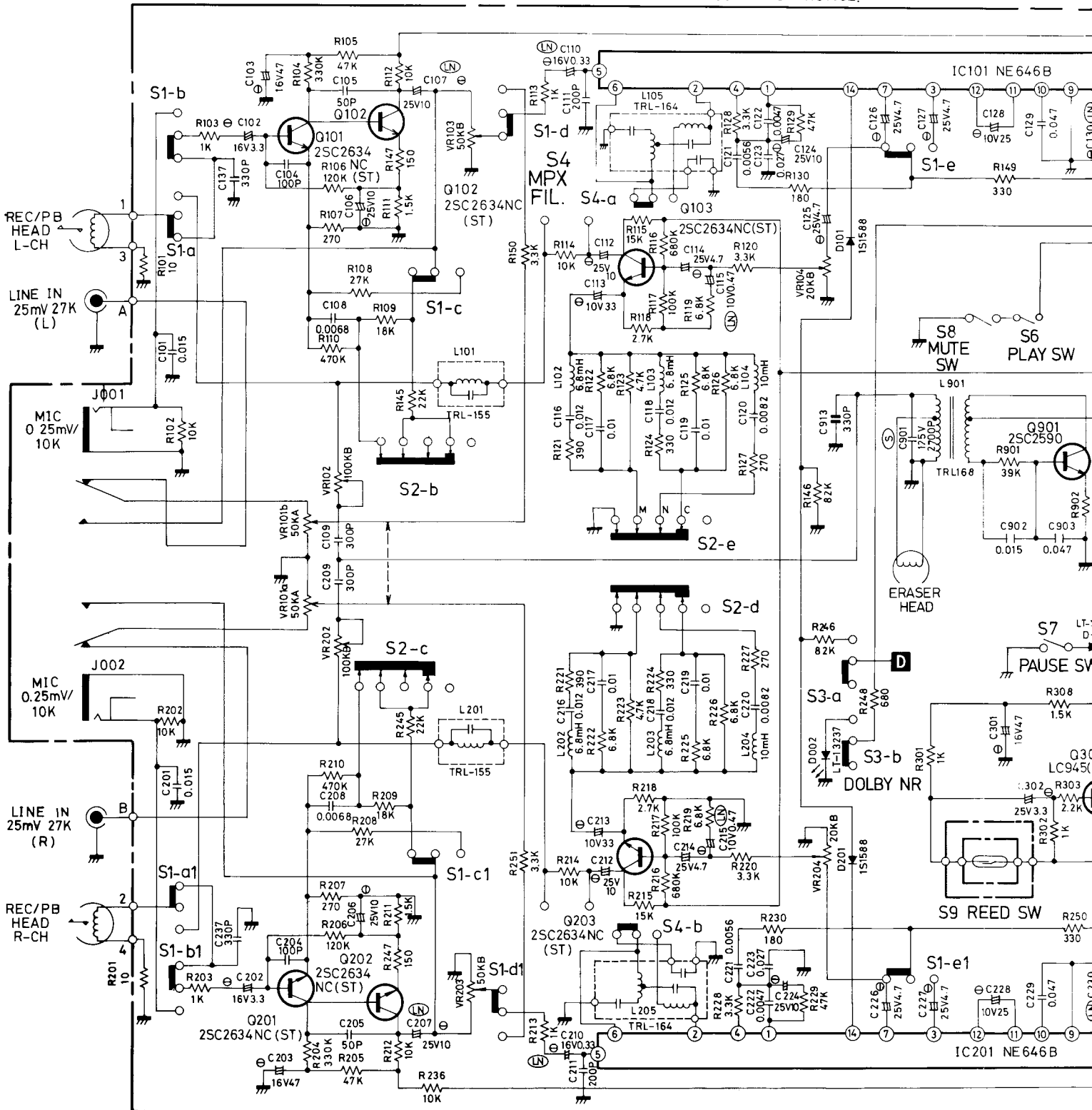

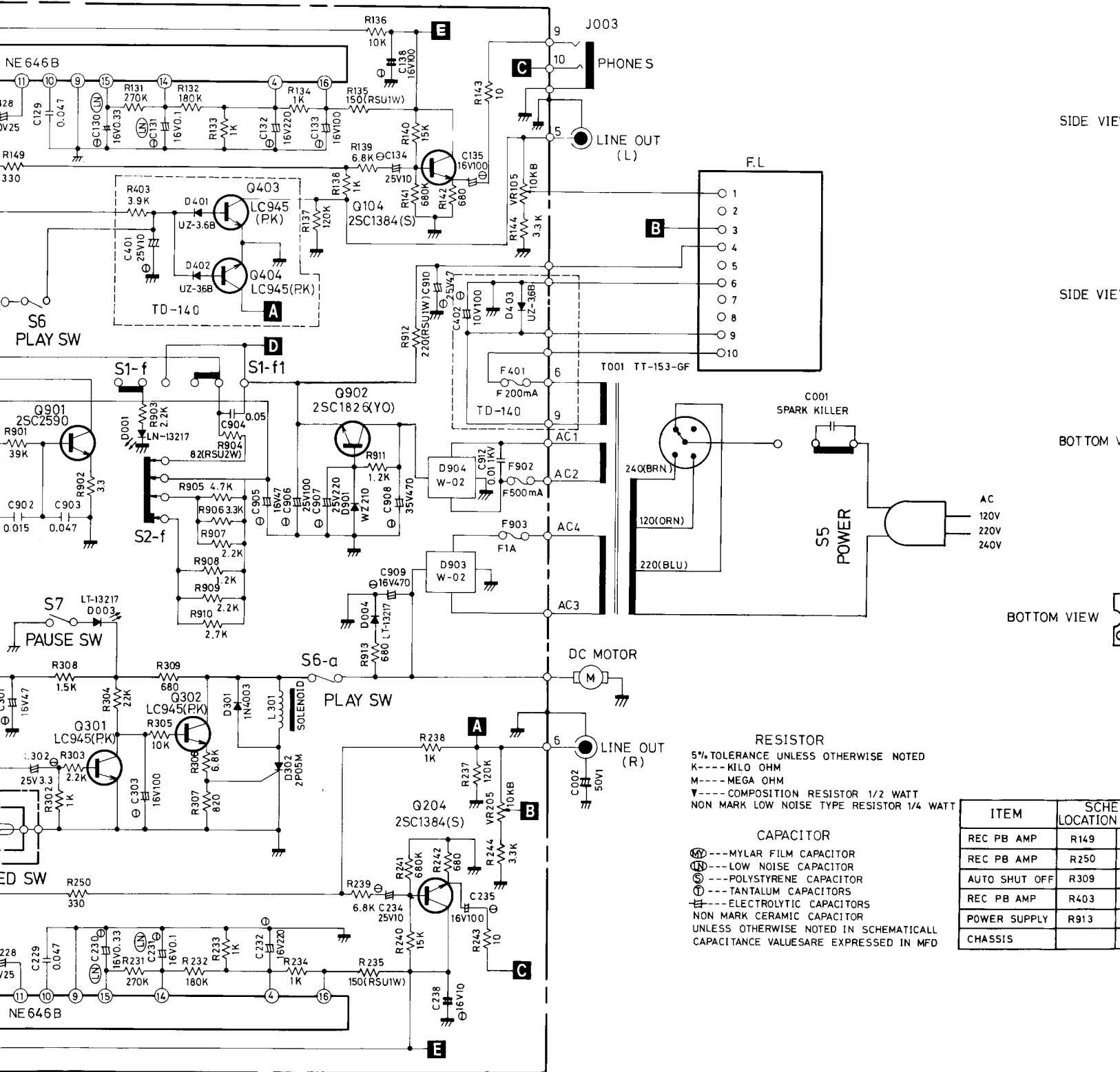

RESISTOR
 5% TOLERANCE UNLESS OTHERWISE NOTED
 K---KILO OHM
 M---MEGA OHM
 V---COMPOSITION RESISTOR 1/2 WATT
 NON MARK LOW NOISE TYPE RESISTOR 1/4 WATT

CAPACITOR
 (M)---MYLAR FILM CAPACITOR
 (LN)---LOW NOISE CAPACITOR
 (P)---POLYSTYRENE CAPACITOR
 (T)---TANTALUM CAPACITORS
 (E)---ELECTROLYTIC CAPACITORS
 NON MARK CERAMIC CAPACITOR
 UNLESS OTHERWISE NOTED IN SCHEMATICALL
 CAPACITANCE VALUES ARE EXPRESSED IN MFD

ITEM	SCHEMATIC LOCATION
REC PB AMP	R149
REC PB AMP	R250
AUTO SHUT OFF	R309
REC PB AMP	R403
POWER SUPPLY	R913
CHASSIS	

SIDE VIEW

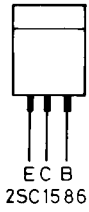

SIDE VIEW

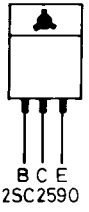

BOTTOM VIEW



AC
120V
220V
240V

BOTTOM VIEW

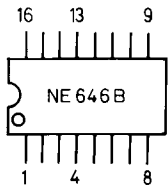

		NE 646 B			
ITEM	SCHEMATIC LOCATION (LAST)				
EC PB AMP	R149 C137	1	INPUT 7.02V	9	GROUND 0.42V
EC PB AMP	R250 C237	2	INPUT 7.11V	10	BY PASS 7.01V
UTO SHUT OFF	R309 C303	3	OUTPUT 7.5 V	11	OUTPUT 7.12V
EC PB AMP	R403 C401	4	REFERENCE 7.01V	12	INPUT 7.01V
POWER SUPPLY	R913 C912	5	INPUT 7.03V	13	REFERENCE
CHASSIS	C002	6	OUTPUT 7.11V	14	BY PASS 7.11V
		7	OUTPUT 6.3 V	15	BY PASS 7.10V
		8	BY PASS 0 V	16	B+ 13.6 V

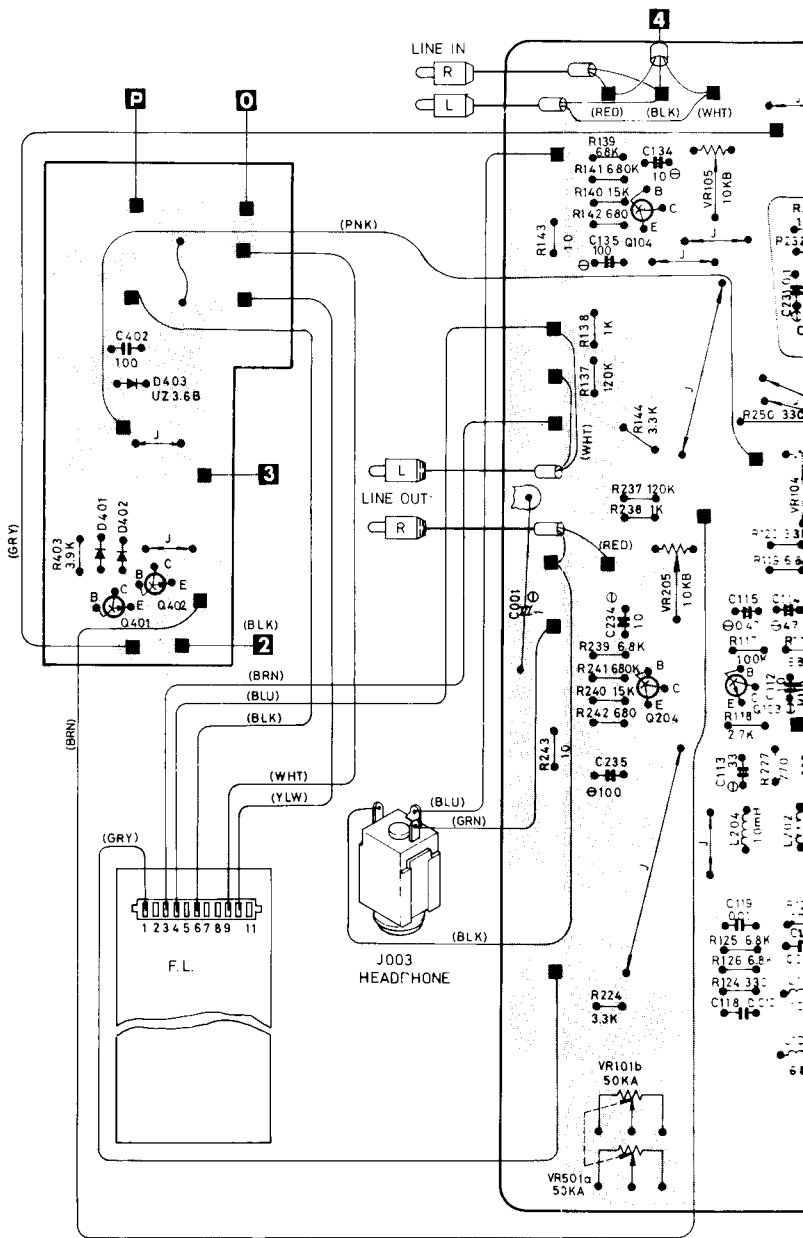

htleitung Diagramm/Diagramme de-connexion

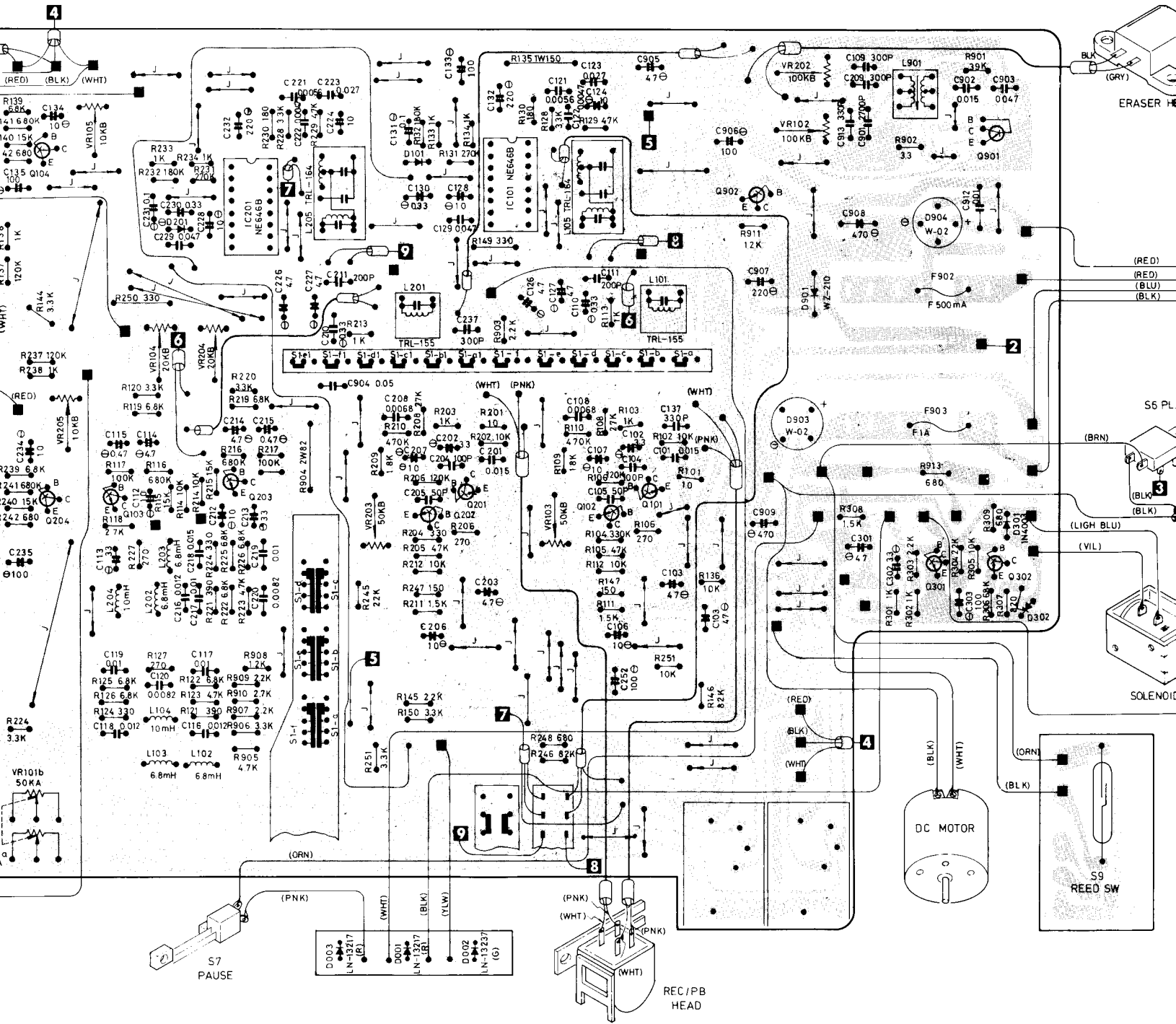

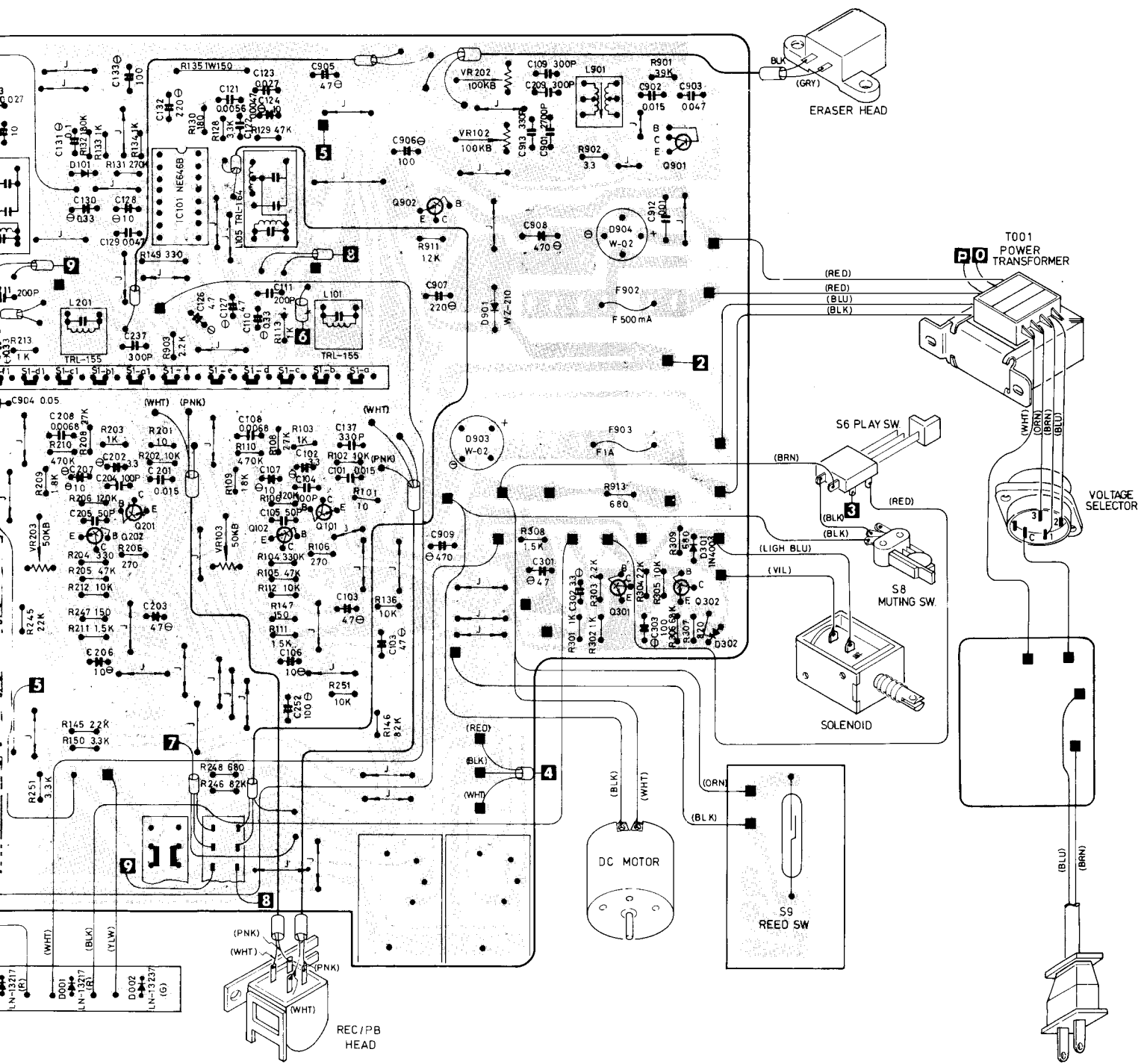

Disassembly Diagram/Illustration des Auseinanderbaus/Sche

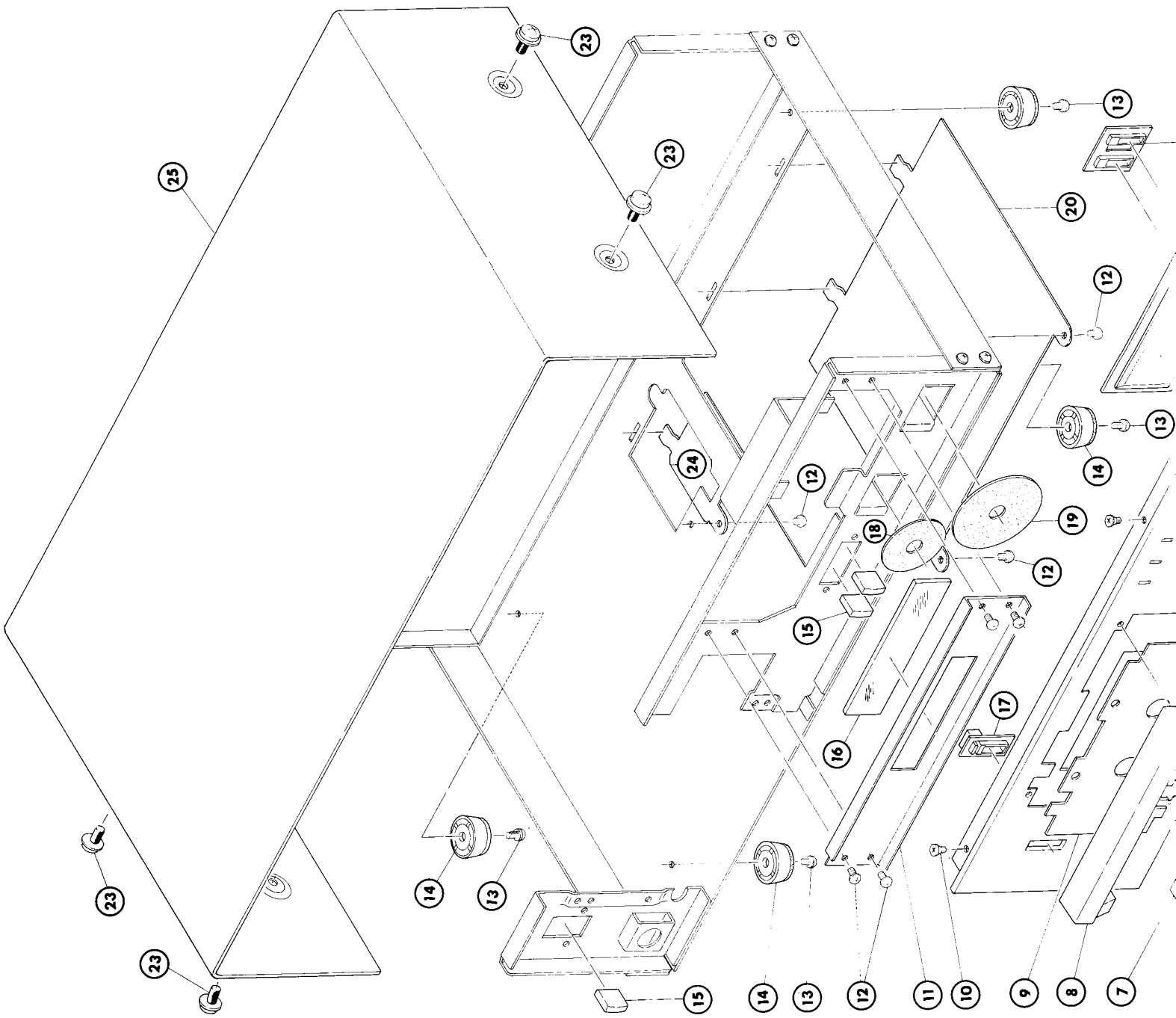

tration des Auseinanderbaus / Schéma de démontage (1/2) -

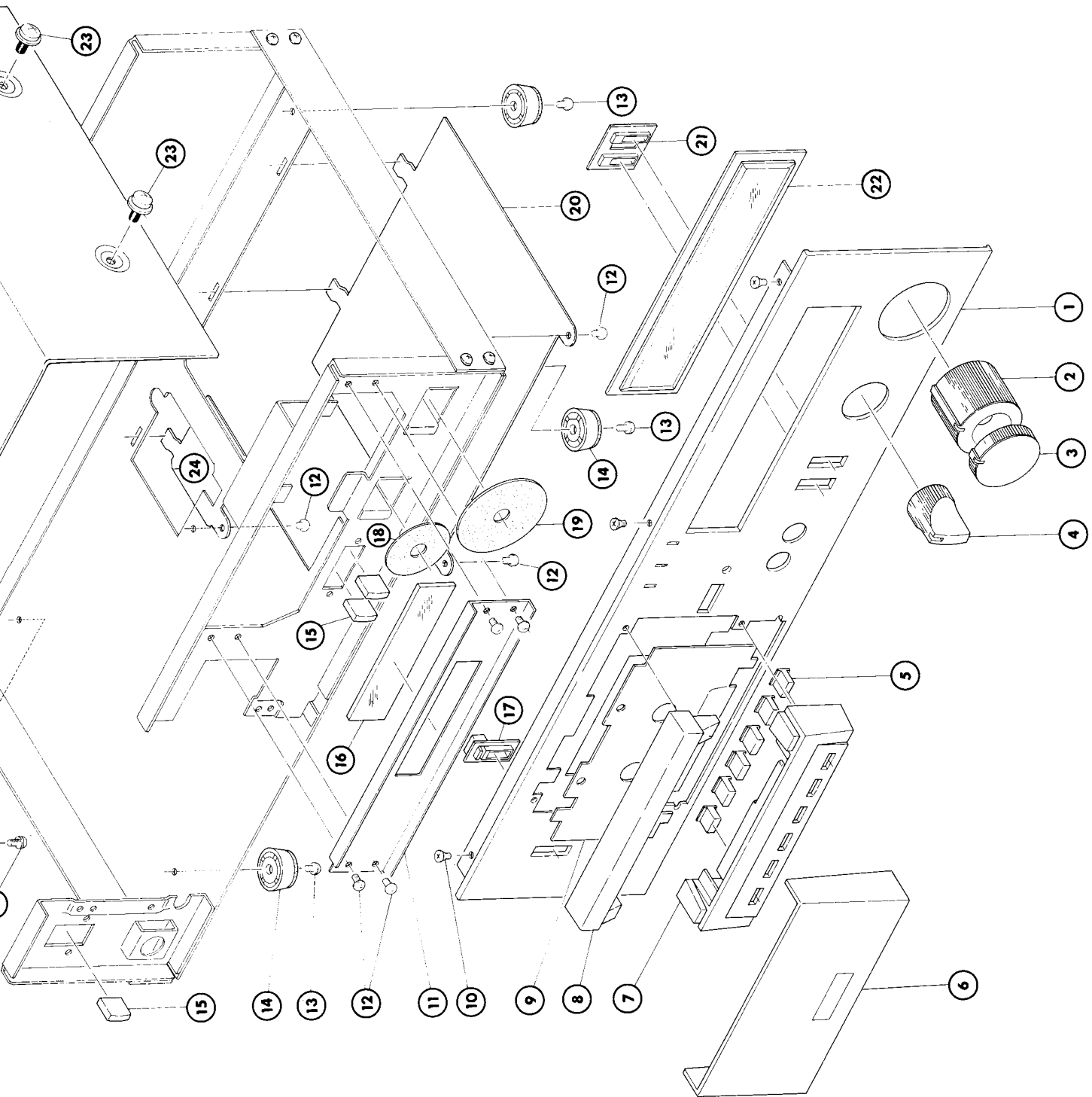

Key No.	Parts No.	Description
1	111911595	Front Panel
2	116310353	Knob, 33 ϕ REC Level (L)
3	116310352	Knob, 33 ϕ REC Level (R)
4	116310335	Knob, 20 ϕ Tape Selector
5	116210089	Deck Push Button
6	114902350	Dust Cover
7	114902348	Plastic Under Cover
8	114902345	Plastic Upper Cover
9	120013086	Deck Ornamental Plate
10	701203006	Screw, MF3x6 Ni
11	120013085	FL Tube Ornamental Plate
12	726203006	Screw, TPV3x6 Ni
13	726203006	Screw, TPV3x6 Ni
14	673402029	Plastic Foot
15	116210073	Push Button
16	114902392	Fitter Board
17	114902373	Push Ring
18	990201329	Felt, Knob (20 ϕ)
19	990201330	Felt, Knob (33 ϕ)
20	120013015	Bottom Cover
21	114902374	2-Key, Push Ring
22	114902391	Panel Window
23	756224006	Screw, MPW4x6 BK
24	120013017	Bottom Cover
25	138011318	Upper Cover

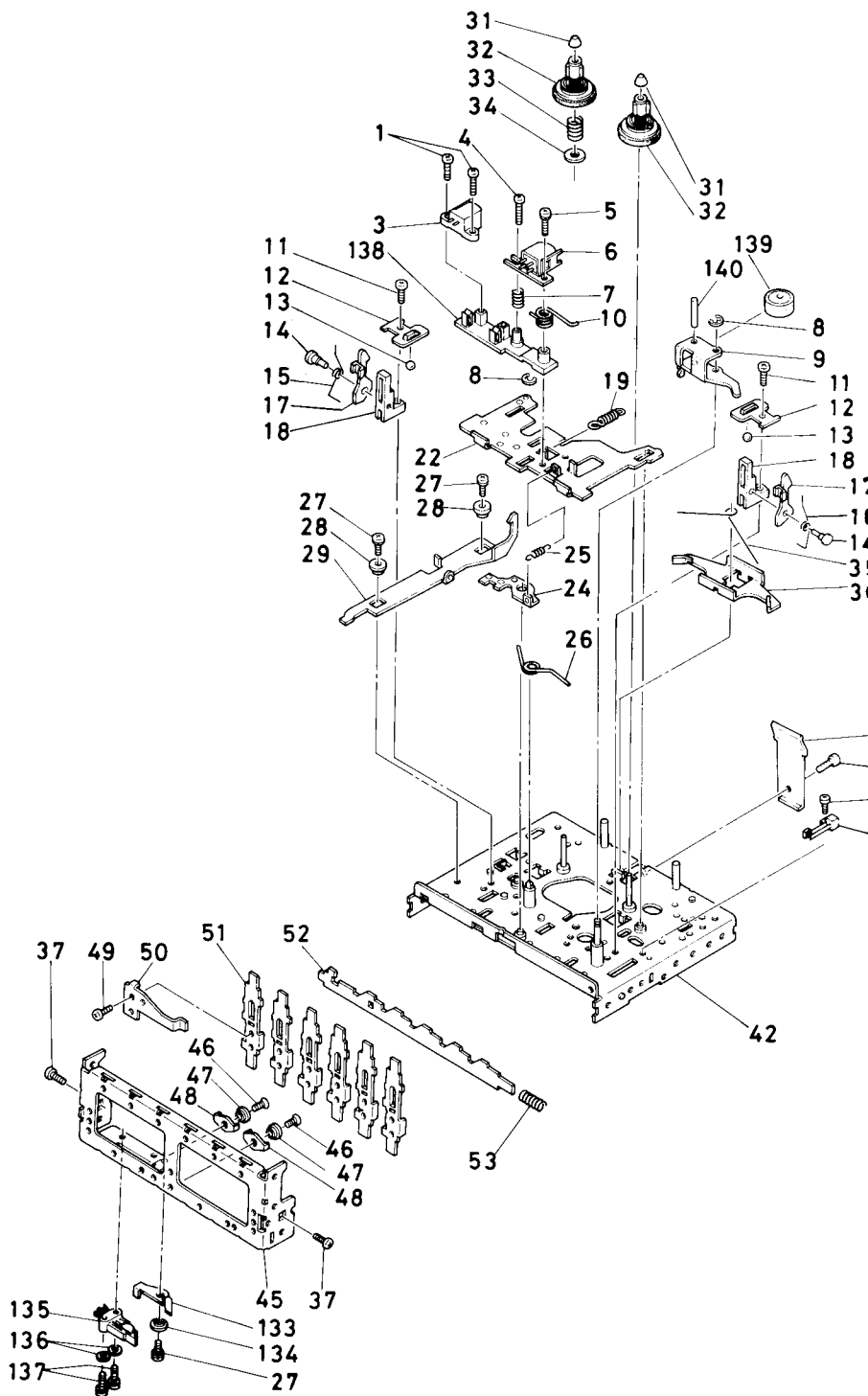

/Illustration des Auseinanderbaus/Schéma de démontage (2/

Key

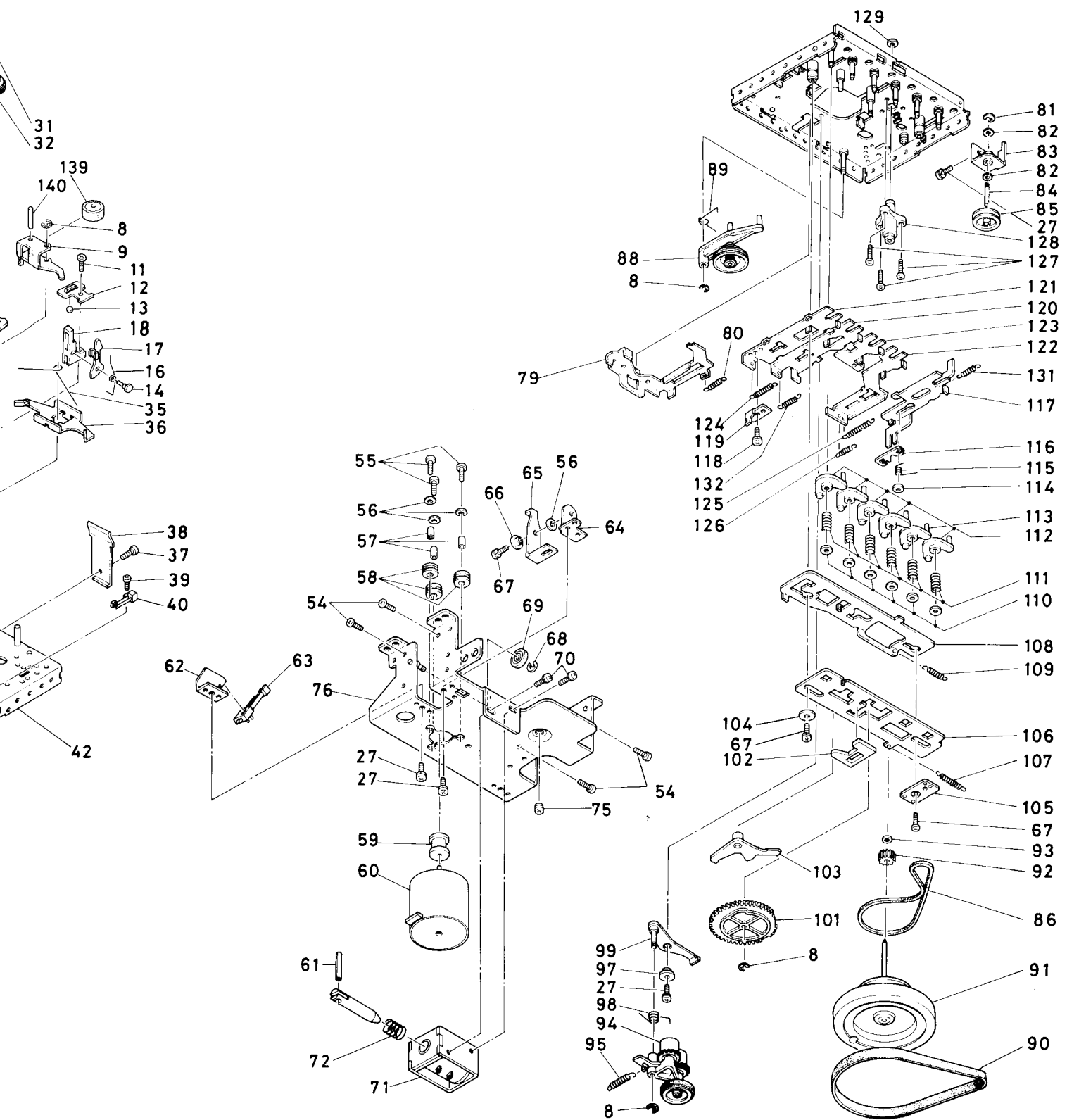

81
82
83
82
84
85
27
128
127
121
120
123
122
131
117
116
115
114
113
112
111
110
108
109
106
107
105
67
93
92
86
91
90

Key No.	Parts No.	Description	Key No.	Parts No.	Description
1	703202014	Screw, M2 x 14, E H Mtg	71	240111250	Plunger Solenoid
2	—	Not Used	72	090236106	Spring E. Solenoid
3	241001123	Erase Head	73	—	Not Used
4	090237211	Screw, ±M2 x 13	74	—	Not Used
5	713202014	Screw, M2 x 14 W/SPW	75	090237201	Screw, Thrust Adj.
6	241001118	REC/PB Head RD-560	76	090231052	Rear Chassis
	241001124	RD-500MKII	77	—	Not Used
7	090236103	Spring B, REC/PB Head	78	—	Not Used
8	770500027	E-ring, E-2.5	79	090231023	Switch Arm 3A
9	090231044	Pinch Roller Arm	80	090236119	Spring 3A, Switch Arm
10	090236136	Spring 3A, Pinch Roller	81	770500026	E-ring, E1.5
11	703202606	Screw, M2.6 x 6	82	770500084	Poly-Slider Washer $\phi 2.1 \times \phi 4 \times t 0.13$
12	090231031	Holder 3A, Head Chassis	83	090231010	Metal Fittings 3BA, Idler Pulley
13	651010113	Steel Ball, $\phi 2$	84	090236135	Shaft, Idler Pulley
14	090236134	Shaft 3B, Cassette Holder	85	090236131	Idler Pulley, 3A
15	090236123	Spring 3B, Cassette Holder	86	671011019	Belt, D1.1 x 59.6-60
16	090236122	Spring 3A, Cassette Holder	87	—	Not Used
17	090231017	Holder 3A, Cassette	88	090231002	Clutch Ass'y
18	090231016	Guide 3A, Cassette	89	090236140	Spring 3C, Clutch Arm
19	090236120	Spring 3A, Head Chassis	90	671011020	Belt, 73 x 4.0 x 0.4-60
20	—	Not Used	91	090236102	Flywheel, 3B
21	—	Not Used	92	090236129	Gear 3A, Capstan
22	090231045	Head Panel, 3F-EGC	93	770500087	Poly-Slider Washer, $\phi 2.6 \times \phi 4.7 \times t 0.25$
23	—	Not Used	94	090231001	RF Pulley Ass'y, 3B
24	090231028	Preventive Lever 3A.	95	090236124	Spring 3B, RF Arm
25	090236108	Spring 3A, Preventive Lever	96	—	Not Used
26	090236137	Spring 3B, Play Arm	97	090231019	Collar 4A, RF Lever
27	713202605	Screw, M2.6 x 5, W/SPW	98	090236127	Spring 3C, RF Arm
28	090237206	Collar 3B, Rec Sensor Arm	99	090231012	RF Lever - 3BA
29	090231046	Rec Sensor Arm 3I	100	—	Not Used
30	—	Not Used	101	090236141	Drive Gear 3A
31	090236128	Reel Cap A	102	090231053	Holder 3B, Cam
32	090236142	Reel Ass'y 3C	103	090231005	Trigger Lever 3AA
33	090236104	Spring B, Reel Ass'y	104	090237208	Washer K, Eject Lever
34	770500086	Poly-Slider Washer, $\phi 6.2 \times \phi 9.5 \times t 0.25$	105	090231040	Support 3A, Drive Arm
35	090236118	Spring 3A Brake Arm	106	090231054	Drive Arm 3C.
36	090231047	Brake Arm 3A	107	090236110	Spring 3A, Drive Arm
37	763203006	Screw, 3 x 6, Tap-tight	108	090231043	Lock Plate, 3B
38	090231039	Cassette Holder 3B	109	090236111	Spring 3A, Lock Plate
39	703202604	Screw, M2.6 x 4	110	090237202	Washer 3A, Operation Lever SP
40	615212288	Leaf Switch (Pause) (LSA-1119A)	111	090236112	Spring 3A, Operation Lever
42	090231048	Chassis Sub-ass'y 3EA	112	090231014	Lever 3A, Operation
43	—	Not Used	113	090231015	Lever Stop 3A, Operation
44	—	Not Used	114	770500083	Poly-Slider Washer, $\phi 2 \times \phi 8 \times t 0.5$
45	090231049	Frame 3J-EGC, Push Button	115	090236113	Spring 3A, Pause Cam.
46	701202604	Screw, M2.6 x 4, Countersunk	116	090231055	Cam 3A, Pause
47	090237204	Collar 3A, Preventive Plate	117	090231056	Pause Arm 3E
48	090231021	Preventive Plate	118	713202604	Screw, M2.6 x 4, W/SPW
49	763202604	Screw, 2.6 x 4, Tap-tight	119	090231033	Metal Fittings 3A, REC SW Mtg
50	090231030	One-touch Lever 3A	120	090231057	REW Arm 3C
51	090231050	Lever 3B, Push Button	121	090231024	REC Arm 3A
52	090231051	Trigger Actuator, 3A-EGC	122	090231022	FF Arm 3A
53	090236109	Spring 3A, Trigger Actuator	123	090231058	Play Arm 3B
54	763203004	Screw, 3 x 4, Tap-tight	124	090236117	Spring 3A, REC Arm
55	703202608	Screw, M2.6 x 8, Motor Mtg.	125	090236116	Spring 3A, FF Arm
56	770500082	F. Washer, $\phi 2.8 \times \phi 10 \times t 0.5$	126	090236125	Spring 3B, RF Lever
57	090237203	Collar, $\phi 2.8 \times \phi 3.8 \times t 6$, Motor Mtg	127	763202605	Screw, 2.6 x 5, Tap-tight
58	090239002	Cushion E, Rubber, Motor Mtg	128	090231004	Bearing 3B, Capstan
59	090236139	Motor Pulley, 2 x 10.65 R-U	129	090237207	Washer, Idler
60	260101130	Motor (MM1-6A2LK)	130	—	Not Used
61	770911281	Spring Pin	131	090236143	Spring 3D, Pause Arm
62	090231038	Metal Fitting 3A, Play SW Mtg (Main)	132	090236144	Spring 3A, REW Arm
63	615212294	Leaf Switch, Play (Main)	133	090231059	Actuator 3B
64	090231034	Holder 3A, Stop Lever	134	090237212	Collar 3A, Actuator
65	090231035	Stop Lever 3A	135	615212302	QA Switch (QAS-1229)
66	090237205	Collar 3A, Stop Lever	136	090237213	Washer, $\phi 2.2 \times \phi 4.3 \times t 0.3$
67	713202606	Screw, M2.6 x 6, W/SPW	137	713202010	Screw, M2 x 10, W/SPW
68	770500039	E-ring E-3.0	138	090231060	Head Base 9A
69	090236132	Pulley 3G	139	090236145	Pinch Rollar G
70	713203005	Screw, M3 x 5, W/SPW	140	090236146	Shaft D, Pinch Rollar